

Artistry in Sound
ONKYO

TX-890/890M

TX-870/870M

Computer Controlled Tuner Amplifier

● **Congratulations on your purchase of the ONKYO TX-890/890M, TX-870/870M Tuner-Amplifier.** ● Please read this manual thoroughly before making connections and turning power on. ● Following the instructions in this manual will enable you to obtain optimum performance and listening enjoyment from your new TX-890/890M, TX-870/870M. ● Please retain this manual for future reference.

CONTENTS

Features	1
Important safeguards.....	2
Precautions.....	2
System connections	3
Front panel facilities.....	7
Operations.....	10
Troubleshooting guide.....	14
Specifications	15

Features

- **Plenty of Clean Power**

TX-890: 125 watts of continuous power per channel into 8 ohms with no more than 0.02% total harmonic distortion (FTC).
(2 x 380 watts dynamic power at 2 ohms.)

TX-870: 105 watts of continuous power per channel into 8 ohms with no more than 0.025% total harmonic distortion (FTC).
(2 x 310 watts dynamic power at 2 ohms.)

These tuner amplifiers are designed to consistently deliver their full rated power even into low impedance loads.

- **Discrete Output Stage**

Instead of IC power amplifier circuitry, the TX-890 and TX-870 both employ a discrete output stage for effortless drive into low impedance loads. Low distortion linear switching and the high quality parts used throughout are further proof of Onkyo's dedication to audio excellence not only in our high end amps but across the board.

- **"CD Direct" Switch**

This switch lets you bypass the tone and balance controls when listening to CD players (or other audio sources). Since noise levels in digital audio components are extremely low, tone and balance circuitry or excessive switches are often unnecessary and may even adversely affect the sound.

- **APR (Automatic Precision Reception) System**

Onkyo's exclusive APR system lets every FM broadcast sound its best. A microelectronic brain monitors the broadcast signal and selects the optimum settings for four reception modes: stereo/mono, hi-blend on/off, local/DX and noise reduction on/off. The APR system settings are shown by indicators on the front panel.

- **20-Station FM/AM Random Memory with Battery- Free Backup**

- **Full Logic Selector Buttons for Seven Input Sources (Including Two Video Inputs) and Video Dubbing Capabilities**

- **Dynamic Bass Expander (TX-890)**

- **Selective Tone Control and Simulated Stereo**

- **Remote Controlled Motor Driven Volume Control**

- **FM Antenna A/B Switchable (Broadcast and Cable) (TX-890)**

- **Pre out/Main in Jacks**

- **RC-AV20M Programmable universal Remote Control Included (TX-890M, TX-870M)**

CAUTION

"TO REDUCE THE RISK OF ELECTRIC SHOCK, DO NOT REMOVE COVER (OR BACK). NO USER-SERVICEABLE PARTS INSIDE. REFER SERVICING TO QUALIFIED SERVICE PERSONNEL."



- The lightning flash with arrowhead symbol, within an equilateral triangle, is intended to alert the user to the presence of uninsulated "dangerous voltage" within the product's enclosure that may be of sufficient magnitude to constitute a risk of electric shock to persons.



- The exclamation point within an equilateral triangle is intended to alert the user to the presence of important operating and maintenance (servicing) instructions in the literature accompanying the appliance.

"WARNING"

"TO REDUCE THE RISK OF FIRE OR ELECTRIC SHOCK, DO NOT EXPOSE THIS APPLIANCE TO RAIN OR MOISTURE."

- For models having power cords with a polarized plug.

CAUTION: TO PREVENT ELECTRIC SHOCK DO NOT USE THIS (POLARIZED) PLUG WITH AN EXTENSION CORD, RECEPTACLE OR OTHER OUTLET UNLESS THE BLADES CAN BE FULLY INSERTED TO PREVENT BLADE EXPOSURE.

- Sur les modèles dont la fiche est polarisée.

ATTENTION: POUR PREVENIR LES CHOCS ÉLECTRIQUES NE PAS UTILISER CETTE FICHE POLARISÉE AVEC UN PROLONGATEUR, UNE PRISE DE COURANT OU UNE AUTRE SORTIE DE COURANT, SAUF SI LES LAMES PEUVENT ÊTRE INSÉRÉES À FOND SANS EN LAISSER AUCUNE PARTIE À DÉCOUVERT.

Important safeguards

1. **Read Instructions** – All the safety and operating instructions should be read before the appliance is operated.
2. **Retain Instructions** – The safety and operating instructions should be retained for future reference.
3. **Heed Warnings** – All warnings on the appliance and in the operating instructions should be adhered to.
4. **Follow Instructions** – All operating and use instructions should be followed.
5. **Water and Moisture** – The appliance should not be used near water – for example, near a bathtub, washbowl, kitchen sink, laundry tub, in a wet basement, or near a swimming pool, and the like.
6. **Carts and Stands** – The appliance should be used only with a cart or stand that is recommended by the manufacturer.

- 6A. An appliance and cart combination should be moved with care. Quick stops, excessive force, and uneven surfaces may cause the appliance and cart combination to overturn.

PORTABLE CART WARNING



7. **Ventilation** – The appliance should be situated so that its location or position does not interfere with its proper ventilation. For example, the appliance should not be situated on a bed, sofa, rug, or similar surface that may block the ventilation openings; or, placed in a built-in installation, such as a bookcase or cabinet that may impede the flow of air through the ventilation openings.
8. **Heat** – The appliance should be situated away from heat sources such as radiators, heat registers, stoves, or other appliances (including amplifiers) that produce heat.
9. **Power Sources** – The appliance should be connected to a power supply only of the type described in the operating instructions or as marked on the appliance.
10. **Grounding and Polarization** – The precautions that should be taken so that the grounding or polarization means of an appliance is not defeated.
11. **Outdoor Antenna Grounding** – If an outside antenna is connected to the receiver, be sure the antenna system is grounded so as to provide some protection against voltage surges and built up static charges. Section 810 of the National Electrical Code, ANSI/NFPA No. 70-1984, provides information with respect to proper grounding of the mast and supporting structure, grounding of the lead-in wire to an antenna discharge unit, size of grounding conductors, location of the antenna-discharge unit, connection to grounding electrodes, and requirements for the grounding electrode. See Figure 73.1.
12. **Power-Cord Protection** – Power-supply cords should be routed so that they are not likely to be walked on or pinched by items placed upon or against them, paying particular attention to cords at plugs, convenience receptacles, and the point where they exit from the appliance.
13. **Cleaning** – The appliance should be cleaned only as recommended by the manufacturer.
14. **Power Lines** – An outdoor antenna should be located away from power lines.
15. **Nonuse Periods** – The power cord of the appliance should be unplugged from the outlet when left unused for a long period of time.
16. **Object and Liquid Entry** – Care should be taken so that objects do not fall and liquids are not spilled into the enclosure through openings.
17. **Damage Requiring Service** – The appliance should be serviced by qualified service personnel when:
 - A. The power-supply cord or the plug has been damaged; or
 - B. Objects have fallen, or liquid has been spilled into the appliance; or
 - C. The appliance has been exposed to rain; or
 - D. The appliance does not appear to operate normally or exhibits a marked change in performance; or
 - E. The appliance has been dropped or the enclosure damaged.

18. **Servicing** – The user should not attempt to service the appliance beyond that described in the operating instructions. All other servicing should be referred to qualified service personnel.

FIGURE 73.1:
EXAMPLE OF ANTENNA GROUNDING AS PER NATIONAL ELECTRICAL CODE INSTRUCTIONS CONTAINED IN ARTICLE 810 – “RADIO AND TELEVISION EQUIPMENT”

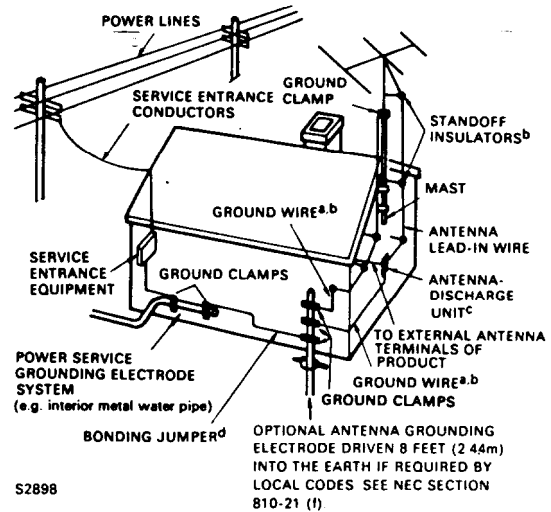

- a Use No. 10 AWG (5.3 mm²) copper, No. 8 AWG (8.4 mm²) aluminum, No. 17 AWG (1.0 mm²) copper-clad steel or bronze wire, or larger, as a ground wire.
- b Secure antenna lead-in and ground wires to house with stand-off insulators spaced from 4–6 feet (1.22–1.83 m) apart.
- c Mount antenna discharge unit as close as possible to where lead-in enters house.
- d Use jumper wire not smaller than No. 6 AWG (13.3 mm²) copper, or the equivalent, when a separate antenna-grounding electrode is used. See NEC Section 810-21 (j).

Precautions

1. Warranty Card

The serial number is written on the rear panel of this unit. Copy the serial number and model number onto your warranty card and keep it in a safe place.

2. Recording Copyright

Recording of copyrighted material for other than personal use is illegal without permission of the copyright holder.

3. AC Fuse

The fuse is located inside the chassis and is not user serviceable. If power does not come on, contact your Onkyo service center.

4. Care

From time to time you should wipe off the front and rear panels and the cabinet with a soft cloth. For heavier dirt, dampen a soft cloth in a weak solution of mild detergent and water or a mild ammonia cleaner, wring it out dry, and wipe off the dirt. Following this, dry immediately with a clean cloth. Do not use rough material, thinners, alcohol or other chemical solvents or cloths since these could damage the finish or remove the panel lettering.

5. Power

WARNING

BEFORE TURNING ON POWER FOR THE FIRST TIME, READ THE FOLLOWING SECTION CAREFULLY.

- Some models are designed for use only with the power supply voltage of the region where they are sold.

USA & Canadian models:	AC120V, 60Hz
Worldwide models:	AC120V, 60Hz/ 220V, 50Hz switchable.

- The tuner amplifiers are provided with the following remote control transmitters:

TX-890/870.....	RC-118S
TX-890M/870M	RC-AV20M

- TX-890M and TX-870M are basically the same tuner amplifiers supplied with different remote control transmitters.

- For the RC-AV20M transmitter, a separate instruction manual is included.
- **De-Emphasis Switch (Rear Panel)**
Worldwide models are equipped with a switch that controls de-emphasis (Others - U.S.A)
Be sure to set this switch to match the de-emphasis in your area.
U.S.A75 μ sec Other areas50 μ sec
- **Tuning Step Frequency Switch (Bottom)**
Worldwide models are equipped with a switch that controls the AM (9kHz/10kHz) band tuning steps.
Be sure to set this switch to match the tuning step frequency in your area.
U.S.A10kHz Other areas9kHz

- **Voltage Selector (Rear Panel)**
Worldwide models are equipped with a voltage selector to conform with local power supplies. Be sure to set this switch to match the voltage of the power supply in your area before turning the power switch on. Voltage is changed by sliding the groove in the switch with a screwdriver to the right or left. Confirm that the switch has been moved all the way to the right or left before turning the power switch on. Models without a voltage selector can only be used in areas where the power supply is the same as that of the unit.

System connections

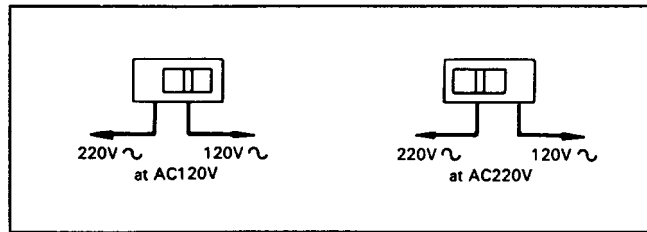
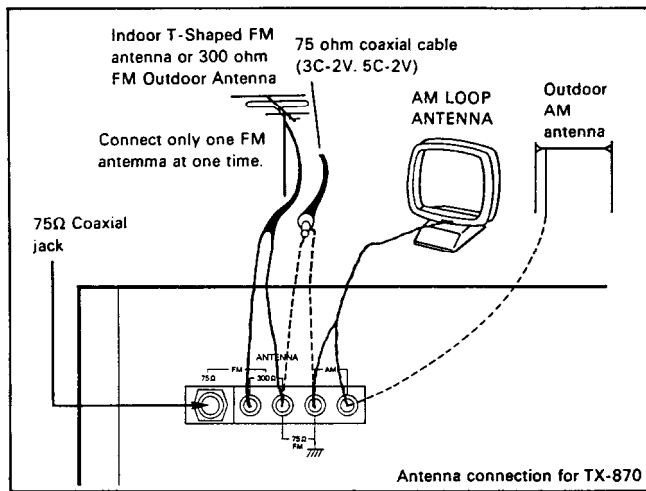

General

Switch the main power switch off before performing connections. Also be sure to perform left and right channel connections properly.

Note to CATV system installer:

This reminder is provided to call the CATV system installer's attention to Article 820-22 of the NEC that provides guidelines for proper grounding and, in particular, specifies that the cable ground shall be connected to the grounding system of the building, as close to the point of cable entry as practical.

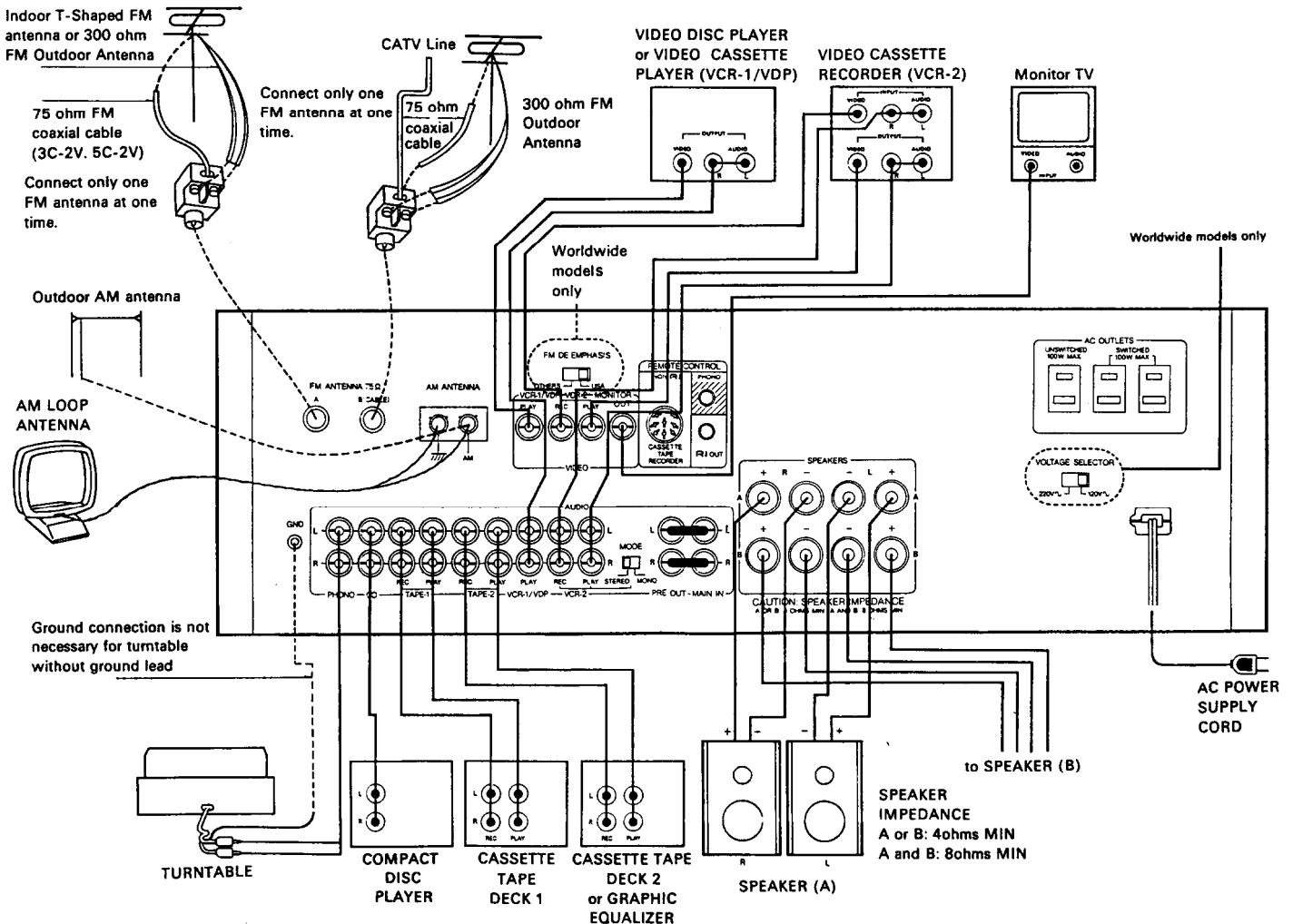

AC Outlets

- **UNSWITCHED:**

This outlet is not switched on and off by the power switch on the front panel. Capacity is 100 watts.

- **SWITCHED:**

These two outlets are switched on and off by the system power switch on the front panel and remote control transmitter. The total capacity of the two outlets is 100 watts.

FM Antenna Connections (FM ANTENNA A, B) (TX-890)

The T-shaped antenna is included in the installation instructions bag. Use the T-shaped antenna if you live in an area where the signal strength of FM broadcasts is high. Connect the antenna to the 300-ohm terminal of the accessory antenna adapter, and insert the antenna adapter into the FM 75-ohm F-type jack of the main unit. Place the antenna on a wall or other surface in the position in which reception is best.

If signal strength is low in your area, use a multi-element FM outdoor antenna and connect to this unit using a 75-ohm coaxial cable, because this type of cable is more resistant to interference than a 300-ohm cable. If the coaxial cable has an F-type plug, insert it into the FM 75-ohm F-type jack of the main unit. If there is no F-type plug, connect the antenna adapter as shown in the illustration (below).

Use the B (CABLE) antenna terminal for connecting CATV (cable TV) FM broadcasts or another FM antenna.

- (1) With your fingernail or a small screwdriver, press the stopper inwards and remove the cover.

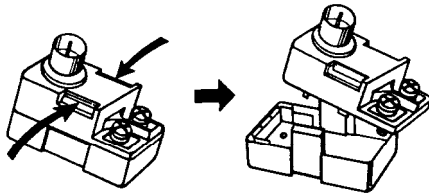

- (2) Prepare the coaxial cable as shown below.

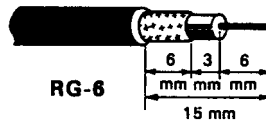

- (3) Connect the 75/300 ohm antenna adapter to the coaxial cable.

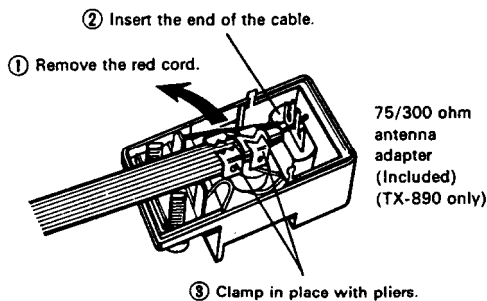

FM Antenna Connections (TX-870)

The T-shaped antenna is included in the installation instructions bag. Use the T-shaped antenna if you live in an area where signal strength of FM broadcasts is high. Connect the antenna to the FM 300 ohm terminals and place the antenna on a wall or other surface in the position in which reception is best. If signal strength is low in your area, use a multi-element FM outdoor antenna and connect to this unit using 75 ohm coaxial cable because this type of cable is more resistant to interference than 300 ohm cable. If the coaxial cable has an F type plug, insert it in the 75 ohm coaxial jack.

NOTE:

Do not use the same antenna for both FM and TV (or VCR) reception since the FM and TV (or VCR) signals can interfere with each other. If you must use a common FM/TV (or VCR) antenna, use a directional linkage type splitter.

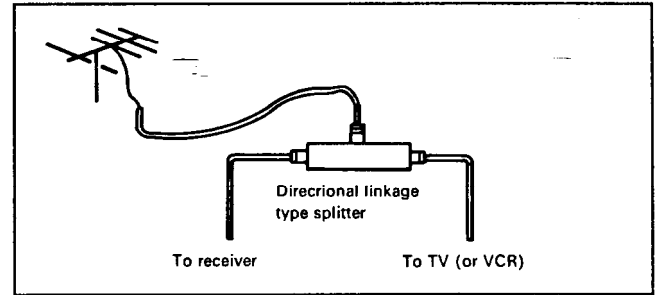

Consult your Onkyo Service Center about the right type for your area.

AM Antenna Connections

An AM loop antenna is included in the installation instructions bag. Take out the connection line and connect it to the AM antenna terminals. This loop antenna can be placed on top of any stable surface or attached to a wall. Try several positions to determine which gives the best reception. Be sure the antenna is not near a speaker, power cord, television set, VCR, or motorized appliances. When using an external AM antenna, do not remove the loop antenna; connect both antennas to the AM antenna terminals.

AM loop antenna assembly

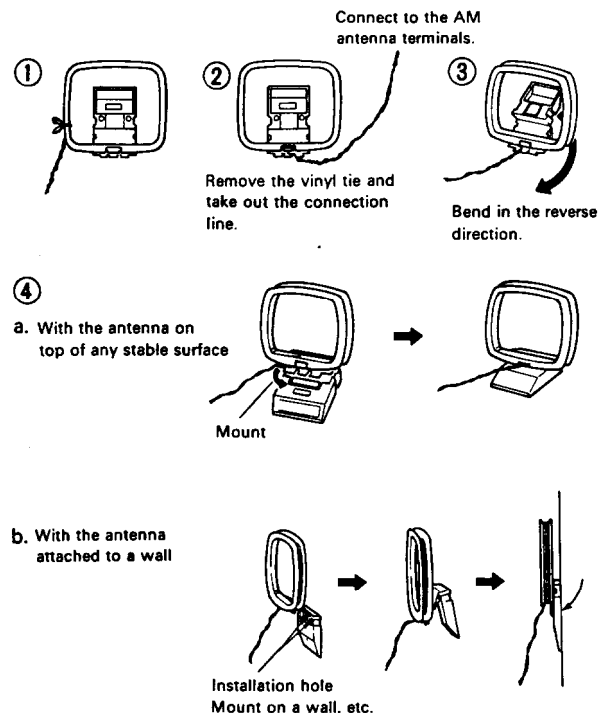

NOTE:

AM reception is easily affected by television sets and VCRs. Therefore, AM reception may be poor if this unit is placed too close to a TV or a VCR.

Speaker Connections (SPEAKERS)

1. Connect the speakers to A and/or B terminals.
 2. When connecting speakers, proper polarity is important. Always connect the (+) terminal (red) on this equipment to the (+) terminal on the speaker and the (-) terminal (black) on this equipment to the (-) terminal on the speaker.
 3. Do not connect a single speaker in parallel to the right and left channel outputs.
 4. Use speaker cables that have a low impedance and that are as short as possible.
- Attach speaker cables to the rear panel speaker terminals with care, being sure that connections are made firmly and that there is no possibility of a short circuit occurring.

CAUTION:

When using banana plugs, make sure the speaker terminal screws are screwed in firmly before inserting banana plugs.

Connections for Remote Control (REMOTE CONTROL)

NOTE:

Of the Onkyo turntables, cassette decks, CD players, etc. that can be remote controlled, some models have the **RI** mark and some do not.

- A cassette tape deck, compact disc player, and turntable that have the Onkyo **RI** mark can be operated using the accessory remote control transmitter RC-118S or RC-AV20M with the TX-890/870 or TX-890M/870M.

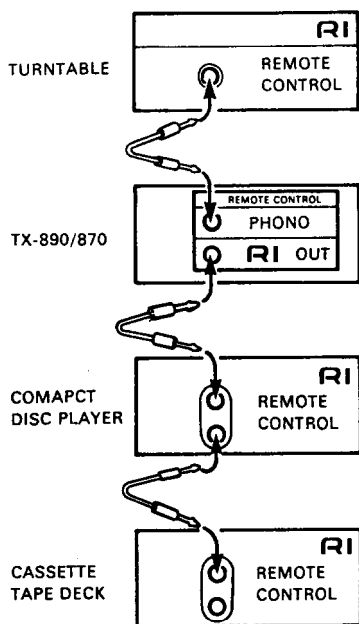

An **RI** remote control cable equipped with a 0.136" (3.5mm) diameter miniature two-conductor phone plug is attached to the TX-890/870 and to any turntable or CD player, with the **RI** mark.

Insert the accessory **RI** remote control cable plug attached to the Onkyo turntable with the **RI** mark into the PHONO of the TX-890/870's REMOTE CONTROL. To use an Onkyo compact disc player and cassette tape deck with the **RI** mark, insert the accessory remote control cable plug into the REMOTE CONTROL jack. As far as connecting sequence is concerned, it doesn't matter whether the cable is connected from the TX-890/870 to the cassette tape deck or to the compact disc player. The connecting sequence is fixed only for the turntable. The remote control transmitter is operated by facing it towards the remote control sensor of the TX-890/870.

- Onkyo turntables and cassette tape decks that can be remote controlled but do not have the **RI** mark. This equipment has a 7-pin DIN jack on the rear panel. Connect this jack and the jack on the rear of the TX-890/870 with the special cable for this purpose, which is sold separately.

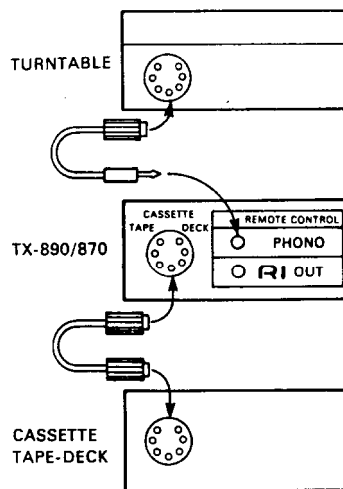

For this special cable, contact an Onkyo Service Center.

For a turntable (3.5 mm pin to 7-pin plug cable) part number: 2010140
For a cassette deck (7-pin to 7-pin plug cable) part number: 2010141

- Onkyo CD players that do not have the **RI** mark can not be remote controlled from the TX-890/870. To remote control with the TX-890M/870M, the codes can be learned by the RC-AV20M to control through the CD player's remote control transmitter.

NOTE:

Remote control operation is not possible when only the remote control cable is connected. Remote control cable and pin cord must be connected.

Turntable Connections (PHONO)

Connect the output leads of the turntable to the PHONO jacks. Be sure to connect the ground (earth) lead wire from the turntable to the ground terminal (GND). Lack of proper ground connection will cause hum. Turntables not provided with GND wires do not need to be connected.

1. Place the turntable on a firm shelf or deck free from vibrations (especially those generated by the speaker system). If the turntable is permitted to pick up such unwanted vibrations, not only with the performance of the unit drop, but distortion in the bass frequencies and howling in the speakers may also occur.
2. Check the turntable instruction manual for any other precautions.
3. The loud noises that occur when connecting and disconnecting the turntable leads, replacing the cartridge or lowering the tonearm could damage the speakers. Always turn the power switch off before making connections.
4. If an Onkyo turntable with remote control jack is used with this unit, the remote control transmitter can also be used to start and stop turntable operation. In this case, the turntable and TX-890/870 must be connected with a remote control cable. Insert the plug into the PHONO jack of the REMOTE CONTROL on the rear panel of the TX-890/870. (Please refer to "Connections for Remote Control.")

Compact Disc Player or Other Component Connections (CD)

Connect the output leads of the CD player or an additional audio component to the CD jacks. An Onkyo CD player with remote control that has the **RI** mark can be operated by the TX-890/870. (Please refer to "Connections for Remote Control".) For more details, refer to your CD player instruction manual.

Tape Deck and Graphic Equalizer Connections (TAPE-1, TAPE-2)

1. This unit has facilities for two tape decks. If you are using only one tape deck, connect it to the TAPE-1 jacks. If you have two tape decks, connect one to the TAPE-1 jacks and the other to the TAPE-2 jacks.
2. Connect the output leads of the tape decks to the TAPE-1 and TAPE-2 "PLAY" jacks. Connect the input leads of the tape decks to the TAPE-1 and TAPE-2 "REC" jacks of the unit. For more details, refer to your tape deck instruction manual.
3. To connect a graphic equalizer, too, use the TAPE-2 jacks and connect the second tape deck to the tape jacks of the equalizer.

To connect a graphic equalizer and second tape deck to the TAPE-2 jacks.

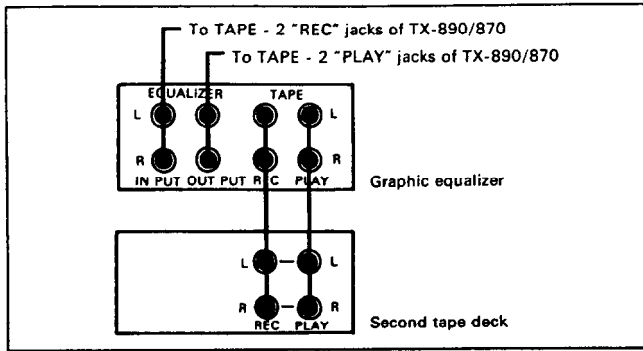

- If you have an Onkyo tape deck with the remote control jack, connect it to the TAPE-1 jacks. Please refer to the section "Connections for Remote Control" (page 5) regarding connection of the remote control cable.

Video Disc Player (or Video Cassette Player) Connections (VCR-1/VDP)

Connect the VIDEO output of the video disc player to the TX-890/870 (VIDEO) VCR-1/VDP "PLAY" jack and the AUDIO output to the (AUDIO) VCR-1/VDP "PLAY" jacks. The VCR-1/VDP jacks are only for playback, there is no REC jack. If the audio output from the video unit is monaural, connect to VCR-2. For more details, refer to the video disc player instruction manual.

Video Cassette Recorder Connections (VCR-2)

- Connect the VIDEO output of the VCR to the rear panel (VIDEO) VCR-2 "PLAY" jack and the VIDEO input of the VCR to the rear panel (VIDEO) VCR-2 "REC" jack. Then connect the AUDIO output of the VCR to the (AUDIO) VCR-2 L and R "PLAY" jacks. Finally, connect the AUDIO input of the VCR to the (AUDIO) VCR-2 L and R "REC" jacks.
- When using a monaural VCR (having a single audio input and output), set the VCR-2 "MODE" switch on the rear panel to "MONO" and use either the R or L audio jacks. If the switch is in the "STEREO" position, sound will be heard from only the right or left speaker system.

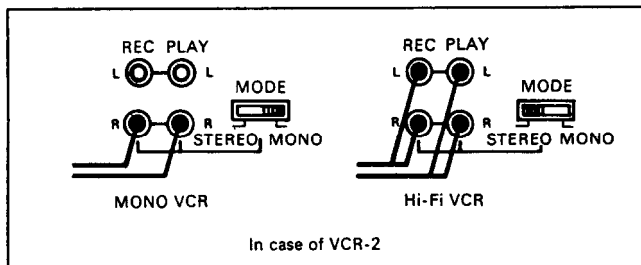

- When using a playback-only VCR, only the output connections need to be performed.
- For more details, refer to the VCR instruction manual.

TV Connections (MONITOR)

- Connect the TV VIDEO input to the TX-890/870 MONITOR "OUT" jack. There is no need to perform an audio connection since sound will be sent directly from the TX-890/870 to the speaker systems.
- The TX-890/870 does not have an RF converter. Therefore, it can be used with only a monitor TV equipped with a video input jack.
- Since the television set, tuner (FM/AM) section of this unit can cause interference that may disrupt sound and/or picture quality, the TV and TX-890/870 and their respective connection cables should be placed as far apart as possible. The use of a common TV/FM antenna is not recommended (see antenna section).

Amplifier Connections (PRE OUT/MAIN IN)

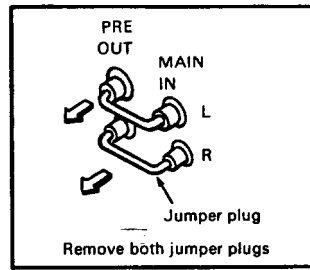

Make sure the power to the main unit is off before connecting the jumper plug. Also, make sure connections are made to the correct terminals.

- Another stereo power amplifier can be connected to the "PRE OUT" jacks. A separate stereo pre-amplifier can be connected to the "MAIN IN".

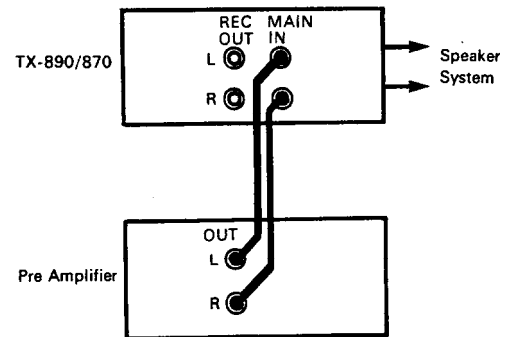
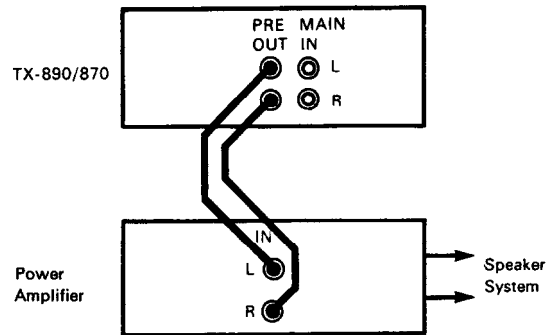

Also, using a Crossover Network, a multi-channel amplifier system can be constructed.

Example) Multi channel amplifier system

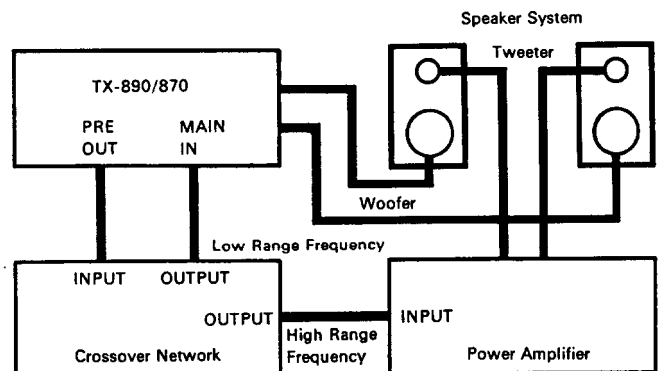

Front panel facilities

NOTE:

- The features, specifications, and display for the TX-890 and TX-870 are slightly different. Read this manual carefully to operate the model you have purchased correctly.

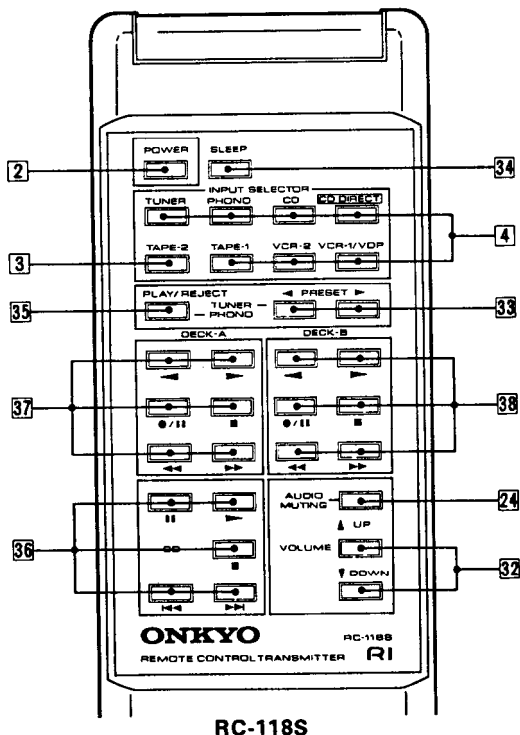
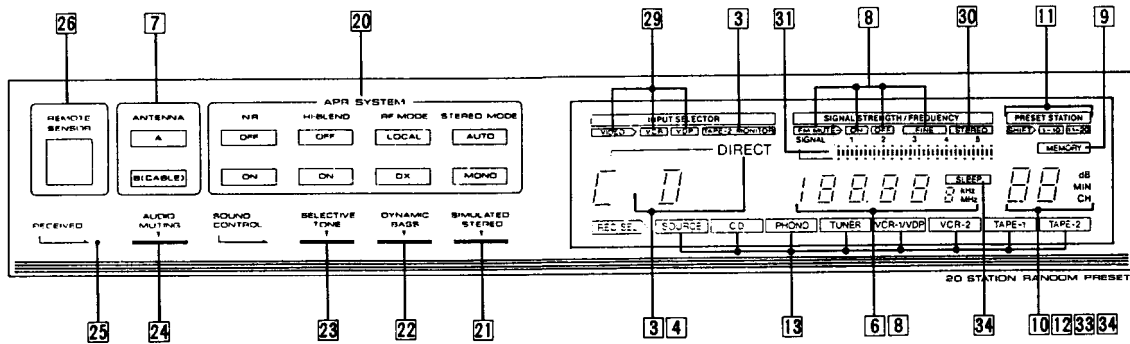
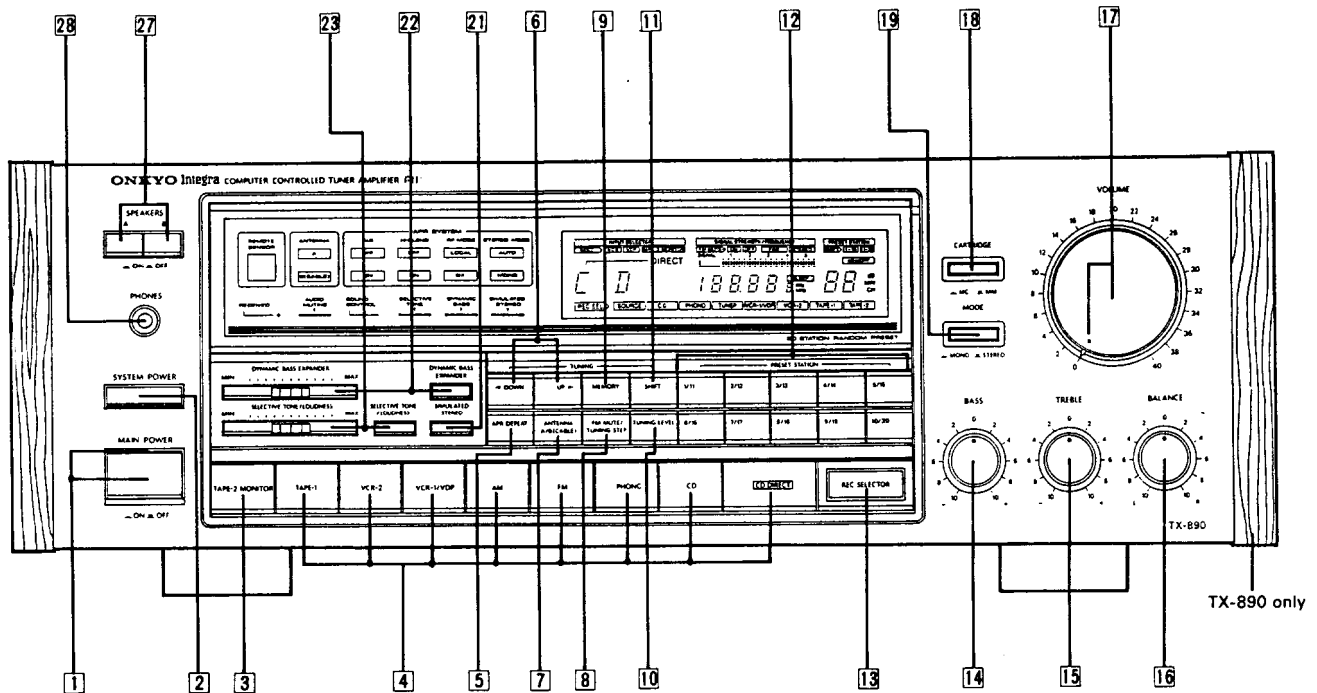

- Main Power Switch and Indicator (MAIN POWER)**
Press this switch to set this unit to the standby mode in which power can be switched on and off by the front panel system power button and remote control power key. The power indicator above the main power switch lights when the unit is in standby mode and during operation.
- System Power Button (SYSTEM POWER)**
When TX-890/TX-870 is in standby mode, press this button to switch the on/off status of the power supply and the AC outlets on the rear panel. Power can also be turned on by using the remote control power key.
- Tape Monitor Button (TAPE-2 MONITOR) and Indicator**
Press this button to use the tape deck connected to the TAPE-2 PLAY/REC jacks for recording, playback or dubbing. The **TAPE-2 MONITOR** on the display lights up and "TAPE- 2" appears at the INPUT SELECTOR display for two seconds. Note that dubbing can only be performed from tape deck 1 to tape deck 2 (TX-870). If tape deck 2 is a 3-head model, the just-recorded signal can be monitored as a recording is being made. The button is also enabled by the key on the remote control transmitter.

4 Input Selector Buttons and Display

The button pressed is shown in display.

● Audio Selectors

TAPE-1: Press to listen to the TAPE-1
AM: Press to listen to an AM broadcast
FM: Press to listen to an FM broadcast
PHONO: Press to listen to the turntable
CD/CD DIRECT: Press to listen to the CD player

When you select CD DIRECT, you can obtain a "pure" sound reproduction, bypassing the bass, treble, balance, selective tone/loudness, simulated stereo, and dynamic bass expander (TX-890 only) and using only the volume control. The "DIRECT" on the display lights up.

● Video Selectors (Controls audio and video signals)

VCR-1/VDP: Press to obtain the video and audio signals from a VCR-1 or a VDP.
VCR-2: Press to obtain the video and audio signals from a VCR-2.

The button is also enabled by the key on the remote control transmitter.

5 APR Defeat Button (APR DEFEAT)

Except while AM is selected, the APR system is alternately turned off and on each time this button is pressed. Turn the APR system off (all APR indicators [20] go out) to listen to a FM radio broadcast in its unaltered form when desired. When APR is off, weak stations will be very noisy. This button should normally be left in the on mode.

6 Tuning Selector Buttons (◀ DOWN, UP ▶) and Display

DOWN: Press to tune in a lower frequency.

UP: Press to tune in a higher frequency.

When listening to a broadcast, pressing the UP button will increase the FM or AM reception frequency. Pressing the DOWN button decreases the frequencies (Manual Tuning). If the button is pressed for longer than 0.5 seconds in AM or FM, and then released, broadcast frequencies will change automatically until a station is tuned in (Auto Tuning).

When either the upper or the lower end of the frequency range is reached, the displayed frequency will automatically switch back to the other end of the range and continue to either increase or decrease as before. For example, when the DOWN tuning selector is pressed, the frequency will decrease until the lowest frequency is reached. The displayed frequency will then switch back to the highest frequency and continue decreasing as before.

Scanning will not stop for broadcasts weak enough to be suppressed by the auto tuning circuit. To receive a weak FM broadcast, either set the tuning level selector button [10] to 17dB (f) or set the FM muting/tuning step button [8] to OFF (FINE). The unit will now be in manual tuning mode, so tune in the FM broadcast.

7 Antenna Selector Button (ANTENNA A/B (CABLE)) and Indicators (TX-890 only)

Press this button to set the FM antenna on the rear panel to A or B (CABLE). The antenna A/B selection status will be memorized at the preset station buttons [12]. Selections cannot be changed by remote control.

8 FM Muting/Tuning Step Button (FM MUTE/TUNING STEP) and Indicators

Press this button to switch the on/off status of muting while concurrently setting the FM tuning step to STANDARD (50 kHz) or FINE (25 kHz). The FINE (25 kHz) setting lets you perform tuning to a finer frequency for receiving a cable broadcast.

FM muting is alternately turned off and on each time this button is pressed and the FM mute indicator is turned [OFF] and [ON]. When FM muting is on, weak FM broadcasts and interstation noise will not be heard.

And when you wish to listen to a cable FM broadcast, selecting FINE lets you tune in the broadcasting station to a finer frequency. While the [FINE] indicator is lit, the frequency changes in 25kHz steps each time a tuning selector button [6] is pressed. This mode will be memorized at the preset station buttons [12].

9 Memory Button (MEMORY) and Indicator

Press this button to place a station in the memory using the preset station buttons [12]. When this button is pressed, the indicator lights for about 8 seconds. While the indicator is lit, press one of the preset station buttons [12]. Upon press, the displayed frequency will be stored in memory. The pressed preset number will be displayed in digital form, and the memory indicator will go out to indicate that memory operation has been completed.

10 Tuning Level Selector Button (TUNING LEVEL) and Display

Each time this button is pressed, the tuning level is alternately set to 17 dB or 27 dB. Use the 27 dB setting if there are a lot of strong FM broadcasts in your area, and the 17 dB setting if there are a lot of weak FM broadcasts in your area. The current setting is shown in the multi function display for about two seconds each time this selector is pressed. To receive broadcasts below the 17 dB level, set the FM muting button [8] to the off setting and tune in the broadcast manually. The displayed tuning level unit of 'dB' is an abbreviation for dBf.

11 Shift Button (SHIFT) and Indicators

The preset station buttons [12] can be used to store a total of 20 radio stations. Use this button to switch the preset buttons between the memory channel 1-10 mode and the memory channel 11-20 mode. The setting switches between 1-10 and 11-20 each time this button is pressed and the respective indicator lights. When power is turned on, the setting is the same as when power was last turned off.

12 Preset Station Buttons (PRESET STATION) and Display





Use these buttons to recall an FM or AM station or to store a station in the memory. When a button is pressed, the corresponding preset number is displayed in digital form. Refer to the Memory section for details.

13 Recording Selector Button (REC SELECTOR) and Display (TX-890 only)

This button selects the source of audio signal output to REC OUTPUT of TAPE-1 and VCR-2. Each time it is pressed, the selection changes in the sequence of [SOURCE], [CD], [PHONO], [TUNER], [VCR-1/VDP], [VCR-2], [TAPE-1], [TAPE-2] → [SOURCE], and the selected position is displayed within the red frame. Set this button to [SOURCE] when REC OUT audio signals will not be used.

NOTE:

1. The audio source which is selected by the recording selector button and displayed within the red frame will be output to REC OUT of TAPE-1 and VCR-2.
2. When [SOURCE] is selected by the recording selector button, signals will be output from the same source as that used for speaker output.
3. Regardless of the setting of the recording selector button, the source selected by an input selector button [4] will be output to REC OUT of TAPE-2.
4. If the recording selector button selects TAPE-1, TAPE-2 or VCR-2, no signals will be output to REC OUT of the respective sources. For example, if TAPE-1 is selected, no signals will be output to REC OUT of TAPE-1.

- 14 Bass Control Knob (BASS)**
Adjust to strengthen or weaken bass response.
- 15 Treble Control Knob (TREBLE)**
Adjust to strengthen or weaken treble response.
- 16 Balance Control Knob (BALANCE)**
Use this control to adjust the relative volume levels of the left and right speaker systems.
- 17 Volume Control Knob (VOLUME) and Indicator**
Turn clockwise to increase the volume level. The volume can be adjusted manually and by the remote control transmitter's volume UP/DOWN key **32**. When adjusted by remote control, the volume control knob rotates along with the volume indicator on the knob. This allows you to see the volume level from a distance.
- 18 Cartridge Selector Switch (CARTRIDGE) (TX-890 only)**
MM  : When a turntable with an MM cartridge is being used.
MC  : When a turntable with an MC cartridge is being used.
- 19 Mode Switch (MODE)**
STEREO  : Normal stereo reproduction; monaural broadcasts will be heard in mono.
MONO  : Both stereo and mono broadcasts will be heard in mono. During FM stereo reception, the stereo indicator will not light. Setting the mode switch to this position switches all other sources to monaural reproduction, too. APR system indicator "MONO" will light too.

20 APR Indicators

Automatic Precision Reception System (FM Mode)

APR system is Onkyo's unique computer-controlled system. APR system automatically sets the RF stage gain (DX/ Local), the NR function (OFF/ON) for reducing noise in weak signals, the HI-BLEND function (OFF/ON) for reducing noise in weak stereo signals, and the auto stereo/mono reception modes to the proper settings for the quality of the broadcast currently being received. This indicator changes each time the APR circuit switches between the LOCAL/DX, NR OFF/ON, HI-BLEND OFF/ON or AUTO/MONO to show the current APR setting. (APR system is effective for only FM reception.)

NOTE:

- When the mode switch **19** is MONO, the APR mode selection function does not operate, and the stereo mode indicator is forced to "MONO".
- The "MONO" display lights up for FM monaural reception.
- The RF MODE will indicate LOCAL when sufficient signal is received.

- 21 Simulated Stereo Button and Indicator (SIMULATED STEREO)**
Set this button to the on position to add a stereo-like effect to monaural sources (TV programs, mono VCR recording, AM radio, etc.).
- 22 Dynamic Bass Expander Button and Level Control Knob and Indicator (DYNAMIC BASS EXPANDER) (TX-890 only)**
Set this button to the on position to add an extra feeling of power and realism to the low range. Its function is unlike that of the conventional bass control. Adjust level control to raise and lower the amount of the dynamic bass expander effect.
- 23 Selective Tone/Loudness Control Button and Level Control Knob and Indicator (SELECTIVE TONE/ LOUDNESS)**
Set this button to the on position, creating a clear reproduction quality of the ultra low frequencies and high frequencies. Boosting of a selective tone can be controlled via the level control.
- 24 Audio Muting Indicator (AUDIO MUTING)**
Muting can be performed by the remote control transmitter audio muting key **24**. When muting is ON, this indicator will light. A lit indicator in the -20 dB setting reduces the volume to about one-tenth the volume level set by the volume control. Use this for eliminating the loud noise that occurs when the

stylus first contacts a record or for reducing other momentary noises.

- 25 Received Indicator (RECEIVED)**
The signal received from the remote control transmitter will also turn the indicator ON.
- 26 Remote Control Sensor (REMOTE SENSOR)**
This sensor receives the remote control signals.
- 27 Speaker Selector Switches (SPEAKERS)**
This unit can drive two pairs of speakers in pairs (A or B) or fours (A + B). To listen to both speaker systems at once, depress both speaker selector switches.
- 28 Headphones Jack (PHONES)**
Stereo headphones with a standard binaural plug can be connected here.
- 29 Video Input Selector Indicators**
When the video source selected by the input selector buttons **4** is VCR-1/VDP, the **VDP** indicator lights up. When the selected video source is VCR-2, the **VCR** indicator lights up.
- 30 Stereo Indicator (STEREO)**
This indicator lights when an FM stereo broadcast is being received. It does not light when the mode switch **19** is in the MONO position or when a weak FM stereo broadcast is being received.
- 31 Signal Strength Indicator**
The optimum tuning point is achieved when the most indicators are lit.

• **Remote Control Transmitter Controls (RC-118S)**

NOTE:

For the RC-AV20M transmitter provided with the TX-890M/870M, —please refer to the separate instruction manual (included).

- 32 Volume Keys (▲ UP, ▼ DOWN)**
This key has the same function as that of the volume control **17**. The volume level can be adjusted by pressing the UP or DOWN key, with the volume control knob rotating simultaneously.
- 33 Tuner Operation Keys (◀ PRESET ▶)**
When the UP (▶) or DOWN (◀) key is pressed, the next higher or lower memory channel is recalled. Each time UP or DOWN key is pressed, the following memory channel in the corresponding direction is recalled. If the key is held down the memory channel will increase or decrease continuously until key is released.
- 34 Sleep Key and Display**
Press to set the power off timer. The sleep timer is a function which turns off the power to the system from the time it is set. When this key is pressed, "90 MIN" is displayed on the tuner's display for 5 seconds, and the power goes off 90 minutes later. Each time the key is pressed during 5 seconds, the timer setting changes, 60, and 30 minutes, in turn. While the sleep timer is operating, the **SLEEP** indicator is lighted. If the sleep key is pressed during this time, the amount of time remaining on the sleep timer is displayed, and if the key is pressed during that display, 30 minutes will be subtracted from that time. If the key is pressed until the display shows 0 minutes, the sleep timer is cancelled, and the power is not turned off.
- 35 Phono Operation Key (PLAY/REJECT)**
This key is used to operate the turntable. The phono operation key can be used only when the PHONO input selector key **4** has been pressed. Each time the phono operation key is pressed, the remote control transmitter alternately emits the play or reject command. Refer to the turntable instruction manual for additional instructions on operating the turntable.
For connections, please refer to the section "Connections for Remote Control."

Consult your Onkyo service center for further details.

NOTE:

Before starting record play using remote control, confirm that there is a record on the platter. If there is no record, the stylus will be lowered to the platter, resulting in serious damage to the stylus.

36 CD Operation Keys (CD)

These keys are used to operate an ONKYO CD player with the **RI** mark.

- ▶ : Press this key to play the CD player.
- ⏸ : Press this key to pause the CD play back. To resume disc play, press the PLAY key.
- : Press this key to stop the CD player.
- ⏮ : Press this key to go back to the beginning of the current track and again to skip back to the previous track.
- ⏭ : Press this key to skip to the next track.

Refer to the CD player instruction manual for additional information.

For connections, please see the section on "Connections for Remote Control."

Consult your Onkyo service center for further details.

37 38 Tape Operation Keys (DECK-A, DECK-B)

These keys control Onkyo double cassette tape decks that can be remote controlled. Use the DECK-B keys to control single cassette tape decks with the **RI** mark and cassette tape decks that do not have the **RI** mark.

- /⏸ : When this is pressed, the recording stand-by mode is entered.
- ◀ : The tape plays, moving from right to left, or, in the recording stand-by mode, recording begins.
- : Interrupts all operations.
- ▶ : The tape plays, moving from left to right, or, in the recording stand-by mode, recording begins.
- ⏮ : Fast forward from right to left.
- ⏭ : Fast forward from left to right.

For connections, please refer to the section "Connections for Remote Control."

Consult your Onkyo service center for further details.

Operations

NOTE:

- Before turning power on, confirm that all connections have been made properly.

Standby Mode

The standby position of controls and switches serves as the starting point for all modes of operation. When the system power button is then turned on (while the main power switch [2] is also on), all controls except the speaker selector, cartridge selector switch, mode switch, bass, treble, volume, balance controls, are in the same setting as when the system power button was last switched off.

[14]	Bass Control	Center
[15]	Treble Control	Center
[16]	Balance Control	Center
[17]	Volume Control	Minimum
[18]	Cartridge Selector (TX-890 only)	As appropriate
[19]	Mode Switch	STEREO
[22]	Dynamic Bass Expander Level Control (TX-890 only)	Minimum
[23]	Selective Tone/Loudness Level Control	Minimum
[27]	Speaker Selector	As appropriate
	VCR-2 Mode Switch (Rear Panel)	As appropriate
[2]	Main Power Switch	ON

Tuner Reception

1. Confirm that the TAPE-2 MONITOR indicator [3] is off, audio muting is off, and press the FM or AM input selector button [4].

2. When FM is selected for TX-890, set the antenna selector button [7] to A or B (CABLE), depending on which antenna is connected to the rear panel. (TX-890 only)
3. To tune in an FM or AM station not stored in the memory, press one of the tuning selector buttons [6]. If you press UP, the frequency is increased. Pressing DOWN decreases. Note that the frequency is changed in 50kHz steps in FM and 10kHz (or 9kHz) steps in AM when the tuning selector button is pressed in single steps. If this button is pressed continuously for more than 0.5 seconds, the auto tuning mode is entered, and frequencies are scanned automatically. When a broadcast signal is received, scanning stops and that frequency is displayed. If a different frequency is desired, press the button once again.
 - Scanning will not stop for broadcasts weak enough to be suppressed by the auto tuning circuit. To receive a weak FM broadcast, use the tuning level selector button [10] to switch from 27 dBf to 17 dBf. If scanning does not stop even after the tuning level is set to 17dBf, set the FM muting/tuning step button [8] to the OFF position, and select the frequency of the desired broadcast station.
 - To achieve preciser tuning to the frequency of a cable broadcasting station when receiving a cable FM (TV) broadcast, use the tuning selector button [6] to approximately locate the broadcasting frequency in 50-kHz steps, then use the FM muting/tuning step button [8] to turn off FM muting and set the tuning step to 25 kHz. At such time, the FM MUTE [OFF] and [FINE] indicators will light up so that manual tuning of the broadcasting frequency can be performed using the tuning selector button. During 25-kHz tuning step mode, automatic tuning is disabled.

NOTE:

When the FINE mode is cancelled, the tuning frequency returns to 50-kHz step mode.

Examples: 100.125 → 100.100 MHz
 100.175 → 100.150
 100.100 → 100.100

4. To recall a station stored in the memory, simply press the FM/AM preset button corresponding to the desired station. Be sure to set the shift button [11] to the range (1-10 or 11-20) for the memory channel to be recalled. This is a random FM/AM memory.

NOTE:

The antenna A/B selection (TX-890 only) as well as the tuning step STANDARD/FINE mode selection will be memorized at each of the preset station buttons.

5. The stereo indicator [30] will light up if the broadcast is being received in stereo. The stereo indicator will not light up if the broadcast is monaural or too weak to be received in stereo.

Memory Function

This unit can store a total of 20 FM and AM stations in the memory for instant recall at any time without using the tuning selector buttons. The 20 stations can be any combination of FM and AM broadcasts. Read the following directions carefully to avoid mistaken operations.

1. Select the FM or AM to be placed in the memory using the input selector button [4]. Confirm the TAPE-2 MONITOR indicator [3] is off and audio muting is off.
2. Use the shift button to set the 1-10 or 11-20 range, depending on which memory channel is to be used.
3. Tune in the broadcast to be placed in the memory using the tuning selector buttons.
4. Press the memory button and, while the memory indicator remains lit (about 8 seconds), press one of the preset station buttons.
5. When the preset station button is pressed, the memory indicator will go out and the pressed preset number will come on. The frequency currently shown in the frequency display is now stored in the memory.

- If the memory indicator goes out before you have pressed one of the preset station buttons, simply press the memory button **[9]** again to give yourself another 8 seconds.
- Placing another broadcast in the same memory channel automatically cancels the station previously stored in that channel.

NOTES:

Preset frequencies can be transferred to other channels. For example, the FM station stored on preset station button number 6 can be transferred to preset button number 1 in the following manner:

- Press preset station button number 6.
- Press the memory button **[9]** (Memory indicator lights).
- Press preset station button number 1.
- The same station is now stored on both preset station buttons 1 and 6.

Memory Preservation

This unit does not require memory preservation batteries. A built-in memory power back-up system preserves the contents of the memory during power failures and even when the unit is unplugged. The unit must be plugged in and the power switch turned on and off once in order to charge the back-up system. Note that since this is not a permanent memory, the power switch must be turned on and off a few times each month to keep the back-up system operative.

The memory preservation period after power has been turned off varies depending on climate and placement of the unit. On the average, memory contents are protected over a period of a few weeks after the last time power has been turned off. This period is shorter when the unit is exposed to a highly humid climate.

Using the Phonograph Record

- Press the input selector button **[4]** to PHONO, and confirm that the TAPE-2 MONITOR indicator is off and audio muting is off.
- Follow the turntable operating instructions.

NOTE:

Confirm that the turntable is connected to the PHONO input jacks on the rear panel.

Using the Compact Disc Player

- Press the CD or CD DIRECT input selector button **[4]**, and confirm that the TAPE-2 MONITOR indicator **[3]** is off and audio muting is off.
- Follow the operating instructions for the CD player.
 - With the input selector button **[4]** set to "CD", the bass control, treble control, balance control, selective tone/loudness control, simulated stereo, dynamic bass expander (only TX-890) can be freely adjusted for the CD playback sound. When the input selector button **[4]** set to "CD DIRECT," these controls will have no effect. Instead, a purer CD sound will be produced.

NOTE:

Confirm that the CD player is connected to the CD input jacks on the rear panel.

Tape Playback

- Press the TAPE-1 input selector button **[4]** or TAPE-2 MONITOR button **[3]** depending on which pair of TAPE PLAY jacks the deck is connected to.
- For playback, follow the operating instructions of the tape deck.

NOTE:

Confirm that the output leads from the tape deck to the TAPE-1 and/or TAPE-2 jacks on the rear panel.

Tape Recording (TX-890)

With the TX-890, you can perform recording while listening to the sound of another source through speakers or headphones. Make all connections between the tape deck and the unit as shown in the System Connections diagram.

- Recording and dubbing to a tape deck connected to TAPE-1
 - To record the source to which you are listening through the speakers or headphones, set the recording selector button **[13]** to the **[SOURCE]** position. Next, use an input selector button **[4]** to select CD, PHONO, FM, AM, VCR-1/VDP, or VCR-2. To perform dubbing from TAPE-2 to TAPE-1, press the TAPE-2 MONITOR button **[3]**.
 - To record the sound of a source which you are not monitoring through the speakers or headphones, use the recording selector button **[13]** to select **[CD]**, **[PHONO]**, **[TUNER]**, **[VCR-1/VDP]**, **[VCR-2]**, or **[TAPE-2]**.

NOTE:

- Before you select **[TUNER]** by the recording selector button, be sure to first select an FM or AM band and tune in a frequency or preset station. Even if the input selector button is not set to FM or AM, the frequency or preset channel will remain displayed.
- When TAPE-1 is selected by the input selector button, recording cannot be performed to the tape deck connected to TAPE-1. Be sure to check the setting of the input selector button when selecting a source by the recording selector button.

- Set the tape deck connected to TAPE-1 to recording mode.
 - Set the proper recording level using the controls on the tape deck used for recording. Also, during recording and dubbing operations, never change the positions of any controls (bass, treble, etc.) on this unit.
- Recording and dubbing to a tape deck connected to TAPE-2
 - The CD, PHONO, FM, AM, VCR-1/VDP, VCR-2, or TAPE-1 source selected by the input selector button **[4]** can be used for recording. Select the source, then set the tape deck to recording mode.
 - Perform dubbing from TAPE-1 to TAPE-2 as follows: Load the original tape in tape deck 1 and the blank tape in tape deck 2. Press the TAPE-1 input selector button **[4]**. Set tape deck 1 to playback mode and tape deck 2 to recording mode.
 - When the TAPE-2 MONITOR button **[3]** is in the OFF position, the source signals can be monitored through the speakers or the headphones. If tape deck 2 has three heads, the just-recorded signals can be monitored (when the TAPE-2 MONITOR button **[3]** is in the ON position). Refer to the tape deck instruction manuals for more details.
 - Set the proper recording level using the controls on the tape deck used for recording. Also, during recording and dubbing operations, never change the positions of any controls (bass, treble, etc.) on this unit.

Tape Recording (TX-870)

- Make all connections between the tape deck and the unit as shown in the System Connections Diagram.
- Radio: Press the FM or AM input selector button **[4]**.
Record: Press the PHONO input selector button **[4]**.
CD: Press the CD input selector button **[4]**.
VCR-1/VDP: Press VCR-1/VDP input selector button **[4]**.
VCR-2: Press the VCR-2 input selector button **[4]**.
- Put the tape deck in the recording mode. The recording can be monitored through the speakers or headphones as desired. For TAPE-2, turn on the corresponding tape monitor button to hear the signal that, having been recorded, is returned from the deck to the TX-870 (if the deck has three heads).
- Set the proper recording level using the controls on the tape deck used for recording. Also, during recording and dubbing operations, never change the positions of any controls (bass, treble, etc.) on this unit.

Tape-to-Tape Dubbing (TX-870)

- Connect the two tape decks to this unit as shown in the System Connections diagram. Dubbing can be done only from TAPE-1 to TAPE-2.
- Load the original tape in tape deck 1 and the blank tape in tape deck 2.
- Press the TAPE-1 input selector button **[4]**.

- Put tape deck 1 in the playback mode and tape deck 2 in the recording mode.
- The source signal can be monitored through the speakers or headphones, when the TAPE-2 MONITOR button [3] is in the OFF position. If tape deck 2 has three heads, the just-recorded signal can be monitored (when the TAPE-2 MONITOR button [3] is in the ON position). Refer to the tape deck instruction manuals for more details.

Using the Graphic Equalizer

- Connect the graphic equalizer to the TAPE-2 jacks on the rear panel.
- If a second tape deck is used, connect it to the tape jacks on the graphic equalizer.
- Press the TAPE-2 MONITOR button [3].
- Follow the graphic equalizer operating instructions.
- To record an equalized signal, use tape deck 2 (connected to the equalizer) for recording.

Video Disc Player Playback

- Connect the video disc player or playback VCR to the TX-890/870 as shown in the System connections diagram. Then connect a monitor or TV having a video input jack to the TX-890/870 video "MONITOR OUT" jack.
- Press the VCR-1/VDP input selector button [4].
- Switch on the monitor TV, and start playback of the video disc player. The picture will be sent to the monitor TV and sound to the speakers connected to the TX-890/870.
- Refer to the video disc player instruction manual for additional information.

Video Cassette Recorder (or Player) Playback

- Connect the VCR to the TX-890/870 as shown in the System Connections diagram. Note that a playback only video unit has no video or audio input jacks. Remember to switch the corresponding VCR mode switch to MONO when using a monaural VCR-2. If this is not done, sound will be heard from only one speaker. If the MONO setting is used with a hi-fi (stereo) VCR, even stereo sound will be heard in the monaural mode. Then connect a monitor or TV having a video input jack to the TX-890/870 video "MONITOR OUT" jack.
- Press the VCR-2 input selector button [4].
- Switch on the monitor TV, and start playback of the VCR. The picture will be sent to the monitor TV and sound to the speakers connected to the TX-890/870.
- Refer to the video cassette recorder instruction manual for additional information.

NOTE:

After selecting VCR-1/VDP or VCR-2, you can display the images of the selected video source while listening to the sound of another source. In such case, the setting of the video selector button is indicated by the lit video input selector indicator [29].

Video Disc Player to VCR Dubbing

Video disc programs can be recorded onto a VCR-2.

- Load a disc in the video disc player, and a blank tape in the VCR-2.
- Press the VCR-1/VDP input selector button [4].
- Begin playback of the video disc player and recording of the VCR-2.
- The VCR-1/VDP to VCR-2 duplication is possible when a second VCR output are connected to the VCR-1/VDP jacks.
- Refer to the video disc player and VCR instruction manuals for additional information.

Video Cassette Recorder Recording

For TX-890, the sound signals of the source selected by the recording selector button [13] are output to REC OUT of VCR-2. For TX-870, the signals of the source selected by the input selector button [4] are output.

NOTE:

When the input selector button is set to VCR-2, neither the video signals nor audio signals will be recorded.

When using a VCR-2 with a built-in TV tuner, it is possible to record a TV broadcast while watching it on the monitor.

- Perform connections as shown in the System Connections diagram.
- Receive the desired TV broadcast using the VCR-2.
- Press the VCR-2 input selector [4].
- Put the VCR-2 in the recording mode and switch on the monitor TV. During recording, the picture is sent to the monitor TV and sound to the speakers connected to the TX-890/870.
- Refer to the video cassette recorder instruction manual for information concerning VCR-monitor TV and antenna connections.

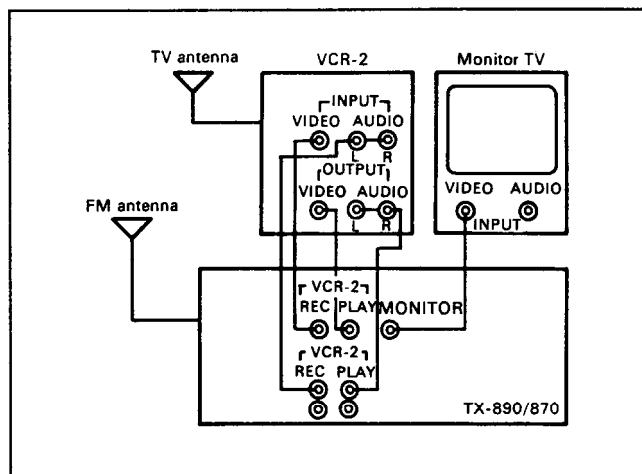

—If the television has no video input terminal, make the connections as shown below:—

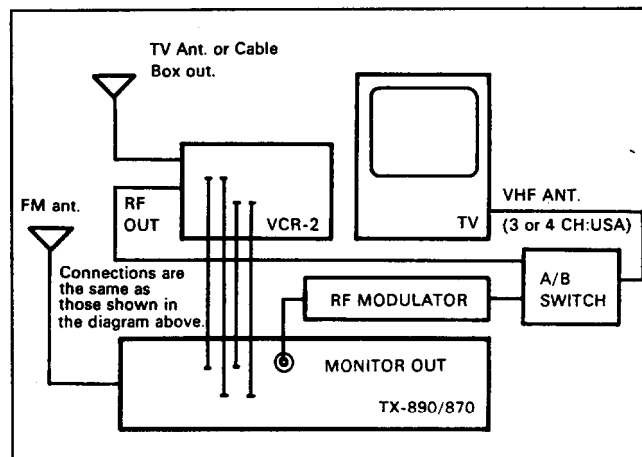

- The "A/B switch" may also be built-in the RF modulator.
- The VCR-1/VDP jack of the TX-890/870 is for playback, so use the VCR-2 jack.
- Use an unused television channel (channel 3 or 4 in the U.S.A.).

• Playback and Recording of TV Picture and FM/CABLE TV Sound

Recording of a TV broadcast and FM broadcast (simulcast) is possible when two VCRs are used.

- Receive the TV broadcast using the VCR-1 tuner.
- Press the VCR-1/VDP input selector [4].
- Press the FM input selector [4] and tune in the FM simulcast using a preset button [12] or the tuning selectors [6]. The picture will be sent to the monitor TV and the FM stereo sound to the speakers connected to the TX-890/870.
- To record the TV picture and FM sound, use VCR-2. Receive the TV broadcast using VCR-1 and begin recording of VCR-2. The program can be monitored during recording.
- VCR-1/VDP is only for playback; there is no REC jack. Thus, connect only the VCR's output lead to VCR-1/VDP.

Using the Remote Control Transmitter (RC-118S)

NOTE:

For the RC-AV20M transmitter provided with the TX-890M/870M, —please refer to the separate instruction manual (included).

- For details on the function of each control, see the description in "Remote Control Transmitter Controls (RC-118S) on pages 9 and 10.
- **Batteries**
The remote control transmitter is powered by two batteries. Before using this unit for the first time, insert the two batteries (included) as shown in the diagram. The remote control transmitter has no on/off switch. Average battery life is one year. This period may be shorter depending on the frequency of use and environment (temperature and humidity) in which the remote control transmitter is used. If the remote control transmitter does not operate even though front panel controls function normally, the batteries should be replaced. Use only batteries listed in the following chart.

Type	Voltage	Size
Manganese	1.5V	AA R6 UM-3

NOTE:

1. Do not leave an expired battery in the case as it may leak or damage the battery case.
2. When inserting the batteries, be sure the (+) and (-) ends are properly aligned.
3. Do not use nickel-cadmium (rechargeable) batteries.
4. Do not use one specified (manganese) battery and one alkaline battery at the same time.
5. Replace both batteries at once; do not use one old and one new battery together.

Transmitter Battery Replacement

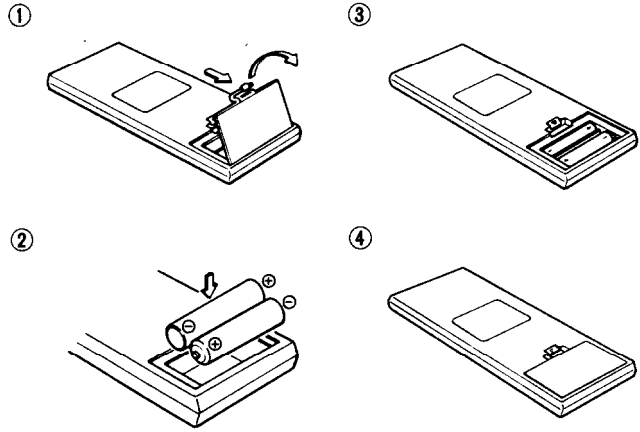

• Precautions

1. Remove the batteries if the remote control transmitter is not going to be used for a long time.
2. This unit uses infrared rays. Therefore, commands may not be received properly if the front panel of the TX-890/870 is exposed to bright light. To prevent this from occurring, place the TX-890/870 so that it is not directly exposed to a bright light.
3. The batteries of the remote control transmitter must be replaced periodically. Remember, however, that commands will be received only when the main power switch of the TX-890/870 is on.
4. The transmitter operates up to a distance of about five meters (16 feet). the transmitting window must always be pointed at the reception window when a command is sent to the receiver.
5. If the TX-890/870 is placed inside an audio rack behind a glass door, the door should not use colored glass or have any decorations on it since this could shorten the range or prevent commands from being received.
6. Use of other infrared remote control devices in the same room may cause interference.
7. If this remote control transmitter does not operate properly, confirm that the batteries are not dead. If the problem persists, contact your Onkyo service center.

Troubleshooting guide

NOTE:

If a problem occurs, first operate the unit using the front panel controls to confirm that it is not due to a malfunction (or worn out batteries) of the remote control transmitter.

Trouble	Cause	Remedy
No power.	<ul style="list-style-type: none"> ● Power cord is disconnected. ● AC fuse blown. 	<ul style="list-style-type: none"> ● Connect power cord. ● Contact Onkyo Service Center.
Power but no sound.	<ul style="list-style-type: none"> ● Tape monitor switch on. ● Audio muting switch on. ● Bad connections. ● Amplifier protection circuitry has been activated. 	<ul style="list-style-type: none"> ● Switch to off. ● Switch to off by remote control transmitter. ● Check input leads, speaker leads, pin plugs, etc. ● Contact Service Center.
Hum, low frequency noise.	<ul style="list-style-type: none"> ● Poor or no input ground. ● Poor or no phono motor ground. 	<ul style="list-style-type: none"> ● Check outer conductor of input plugs. ● Check for proper ground connection.
Howling when the volume is turned up.	<ul style="list-style-type: none"> ● Turntable and speakers are too close together. 	<ul style="list-style-type: none"> ● Move them farther apart.
Rough or scratchy sound. High range is not clear.	<ul style="list-style-type: none"> ● Stylus of pick-up is worn. ● Stylus tip is dirty. ● Treble control too high. 	<ul style="list-style-type: none"> ● Replace. ● Clean. ● Turn treble control down.
Buzzing noise on AM (particularly conspicuous at night or with weak stations).	<ul style="list-style-type: none"> ● Noise from electrical apparatus such as fluorescent lamp. 	<ul style="list-style-type: none"> ● Move AM loop antenna to different position. ● Set up outdoor AM antenna.
High pitched noise or buzzing noise on TV.	<ul style="list-style-type: none"> ● Noise from TV. 	<ul style="list-style-type: none"> ● Place the AM loop antenna as far as possible from the TV. ● Move unit away from TV set.
Crackling noise on AM and FM.	<ul style="list-style-type: none"> ● Noise caused by turning fluorescent lamp on and off. ● Noise from automobile ignition. 	<ul style="list-style-type: none"> ● Move antenna as far as possible from the fluorescent lamp. ● Install and FM outdoor antenna as far as possible from the road. ● Change the position or direction of the outdoor antenna.
FM signal strength indicators and stereo indicator light but sound is distorted and separation is bad.	<ul style="list-style-type: none"> ● Station is too strong. ● Multiple reflection of the radio waves because of tall buildings or mountains. 	<ul style="list-style-type: none"> ● Change to T-shaped antenna. ● Use antenna which has better directivity and select a point where the distortion is least.
FM signal strength indicators and stereo indicator flicker and hiss is heard on FM.	<ul style="list-style-type: none"> ● Station is too weak. ● Stereo FM broadcasts cover only about half the distance of an ordinary broadcast. 	<ul style="list-style-type: none"> ● Install an outdoor FM antenna. ● Change the position or direction of the outdoor antenna.
No station is recalled when a preset key is pressed.	<ul style="list-style-type: none"> ● The power switch has not been turned on for a long time or the power cord has been unplugged for a long time. 	<ul style="list-style-type: none"> ● The memory contents are lost if the power switch is not turned on a few times each month. Store all stations again and remember to turn the power on a few times each month.
Front panel controls function but remote control transmitter does not.	<ul style="list-style-type: none"> ● No batteries in remote control transmitter. ● Batteries have worn out. 	<ul style="list-style-type: none"> ● Insert batteries. ● Replace batteries.

The tuning steps by which the tuned frequency changes on each band have been set at the factory to the proper value for the country where each unit is to be sold. If you use the unit in a country where a different tuning step is required or if the broadcast frequencies in your country change so that you can not tune in radio stations precisely, take this unit to an authorized Onkyo Service Center.